

## Firmamento Milano

**Nuovi prodotti!**  
**New products!**

Luglio / July 2020

**Nuovi prodotti**  
New product

Pierluigi Cerri	Arachide Arachide Presbitero	plafone / ceiling tavolo, terra / table, floor terra / floor
Michele De Lucchi	Equilibrio M Equilibrio S	tavolo / table tavolo / table
Carlo Guglielmi	Boa Boa Boa Cono Cono Cono Cono Luna tonda Luna quadra Piccola Boa Piccola Boa Piccola Boa Sesé Sesé Sesé Tambù Tambù Tambù Tambù	sospensione / pendant tavolo / table terra / floor sospensione / pendant sospensione / pendant parete / wall terra / floor terra lettura / floor lecture plafone, parete / ceiling, wall plafone, parete / ceiling, wall sospensione / pendant parete / wall terra lettura / floor lecture sospensione / pendant tavolo / table terra / floor sospensione / pendant parete / wall terra / floor terra lettura / floor lecture
Benedetta Miralles Tagliabue	Kate Kate Kate	terra / floor parete / wall sospensione / pendant
Parisotto + Formenton Architetti	Pillola Pillola Pillolina	tavolo / table sospensione / pendant tavolo / table
Park Associati	Servoluce Servoluce Servoluce	sospensione / pendant terra / floor tavolo / table
Daniela Pupa	Etoile Etoile	tavolo / table plafone, parete / ceiling, wall
Franco Raggi	Newton Trilite	sospensione / pendant tavolo / table
Michele Reginaldi	Badessa Ginevra Xlight Xlight	tavolo / table tavolo / table sospensione / pendant terra / floor
Attilio Stocchi	Pleiadi	sospensione / pendant
Filippo Taidelli	Phi Phi Phi	sospensione / pendant parete / wall terra / floor
Cino Zucchi	Stick Stick Stick	terra / floor parete / wall parete / wall

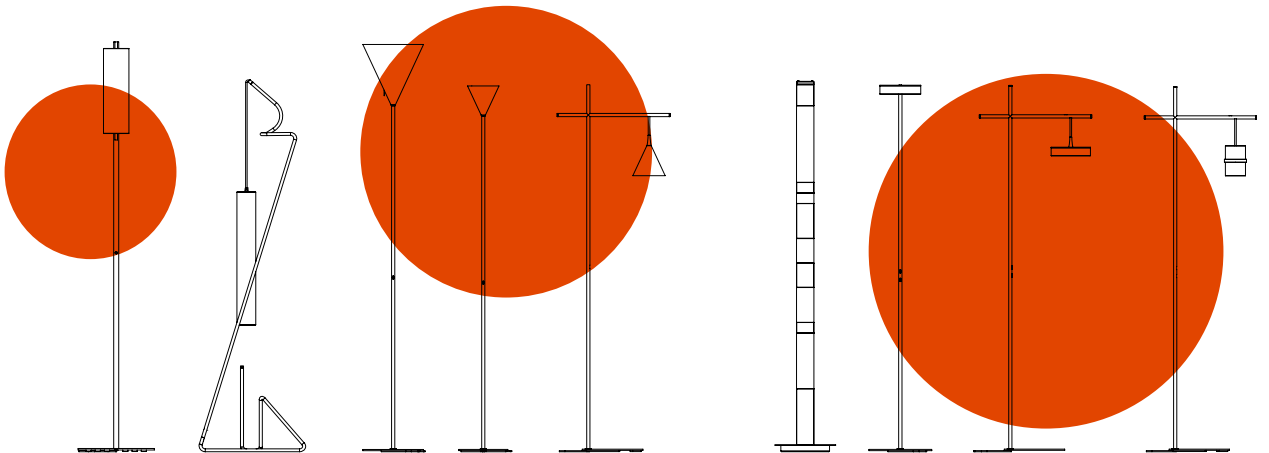
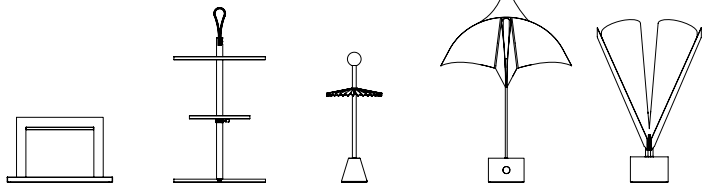
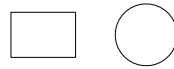
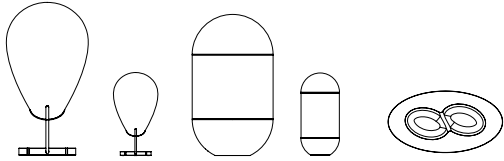
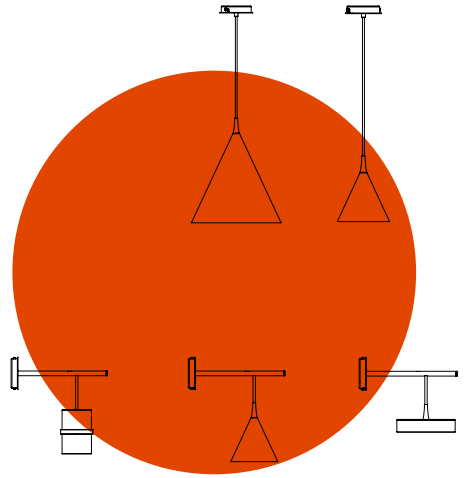
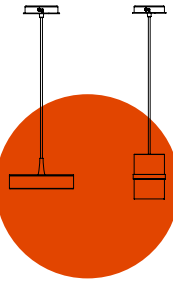
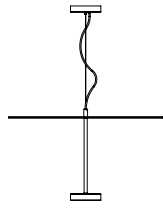
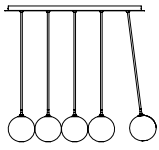



I mesi passati in isolamento anche se un isolamento dorato e privilegiato perché mitigato dalla presenza delle persone più care, vissuto in una bella casa in campagna, circondato quindi dalla natura, dagli animali, dai fiori, dal buon vino e dalle buone letture, hanno consentito, avendo tempo a disposizione, lunghe riflessioni e l'imporsi di un interrogativo finale: lasciarsi cullare da quella pace in cui eri stato catapultato improvvisamente e "arrendersi" o dare a questa tragedia, al virus, al Covid 19, alle conseguenze economiche, che purtroppo anche se in modo diverso hanno colpito tutti, nessuno escluso, una risposta forte, una risposta da "contropiede", una risposta di prospettiva, una ulteriore prova di investimento per il futuro. Abbiamo scelto questa seconda strada e la nuova collezione di prodotti che Vi proponiamo è nei fatti la nostra risposta. Tutti coloro che credono in risposte come queste ci seguano e condividano con Noi i successi che meritano solo le imprese che hanno coraggio. *Carlo Guglielmi*

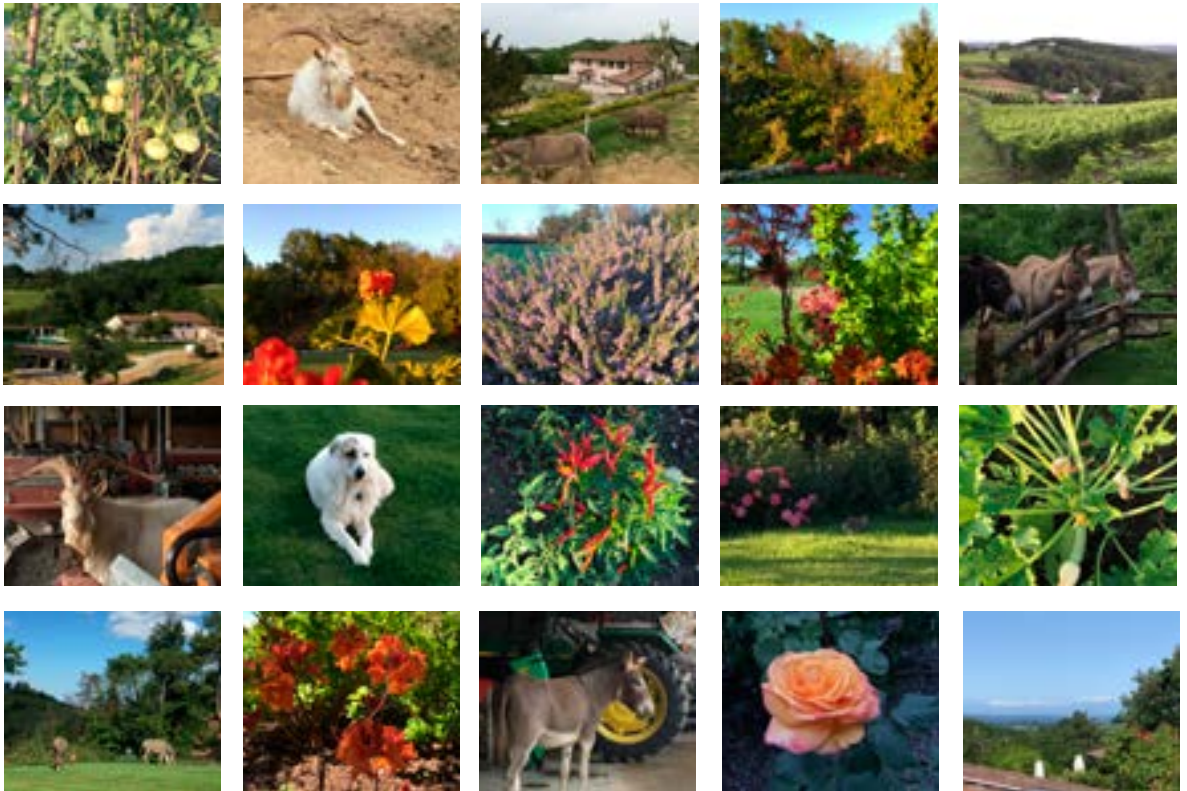

The months spent in solitary confinement, though a gilded isolation privileged because mitigated by the presence of the loved ones, in a beautiful house in the countryside, surrounded by nature, animals, flowers, good wine and good readings, allowed long reflections and the imposition of a serious question: let yourself be lulled by that peace in which you had been suddenly catapulted and “give up”, or on the contrary give to this tragedy, to the virus, the Covid 19 and to the economic consequences, which although in different ways hit everyone, a strong response, a counter-attack, good prospects, an additional proof of investment for the future. We chose this second way and the new collection of products that we are proposing is our answer. Let everyone who believes in answers to follow us and share with us all the success that only companies having courage deserve. *Carlo Guglielmi*

Carlo Guglielmi, 2020

# Cono

Sistema composto dalle versioni da terra, lettura, sospensione, parete e composizioni. Ispirato dal Cono grande il sistema è caratterizzato da una figura, il "Cono", tra le più antiche e copre più funzioni. Tutte le versioni sono dotate di schede LED regolabili con 4 livelli di emissione e quantità di luce. Le versioni da terra e da lettura hanno i regolatori incorporati nello stelo, le versioni da sospensione e da parete necessitano per la loro regolazione, della installazione di dimmer a parete. Su richiesta per la versione a sospensione è possibile realizzare delle composizioni a più elementi.

It is a system composed by the reading, floor, suspension, wall versions and compositions. Inspired by the large Cono, the system is characterized by one among the oldest figures, the "Cone", and covers multiple functions. All versions are equipped with adjustable LED with 4 emission and quantity of light levels. The floor and reading versions have the dimmer in the stem, the suspension and wall versions require a wall dimmer to be installed to adjust the light. On request for the suspension version is possible to create different compositions with several elements.

Carlo Guglielmi, 2020

# Cono

sospensione / pendant

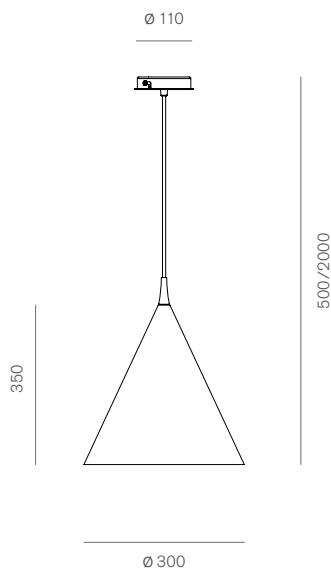

sospensione / pendant

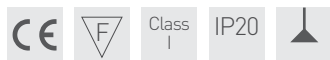
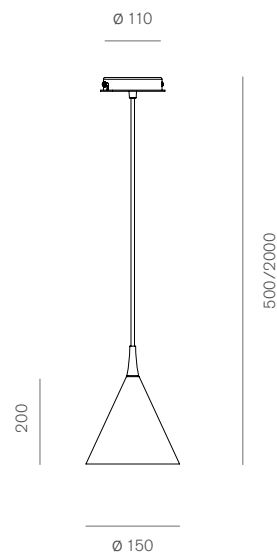

- CG-048PS-WH- (Bianco / White)
- CG-048PS-BL- (Nero / Black)
- CG-048PS-GO- (Oro / Gold)

Lampada da sospensione a luce diretta.  
Pendant lamp with direct light

Verniciato bianco, nero, oro / Varnished white, black, gold  
Acciaio e alluminio / Steel and aluminium

Led / 17W / 230V / 1700 Lumen / 90 Cri / 2700 K  
A+ / Dimmer / Cavo in tessuto nero 200 cm  
/ Black fabric cave 200 cm



- CG-048PXS-WH- (Bianco / White)
- CG-048PXS-BL- (Nero / Black)
- CG-048PXS-GO- (Oro / Gold)

Lampada da sospensione a luce diretta.  
Pendant lamp with direct light

Verniciato bianco, nero, oro / Varnished white, black, gold  
Acciaio e alluminio / Steel and aluminium

Led / 17W / 230V / 1700 Lumen / 90 Cri / 2700 K  
A++ / Dimmer / Cavo in tessuto nero 200 cm  
/ Black fabric cave 200 cm

Carlo Guglielmi, 2020

# Cono

parete / wall

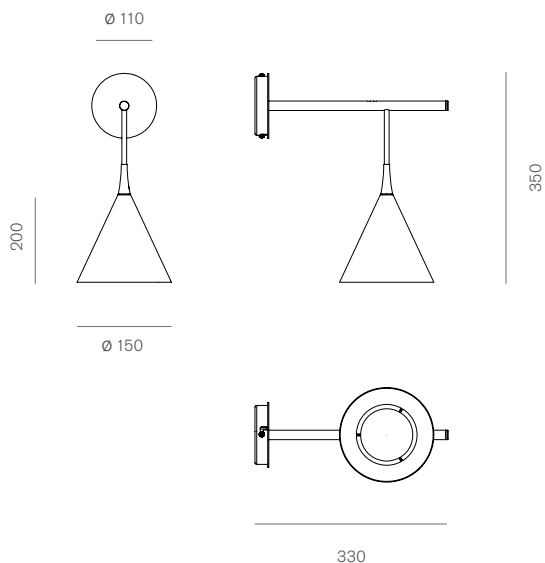

terra lettura / floor lecture

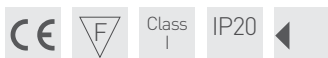
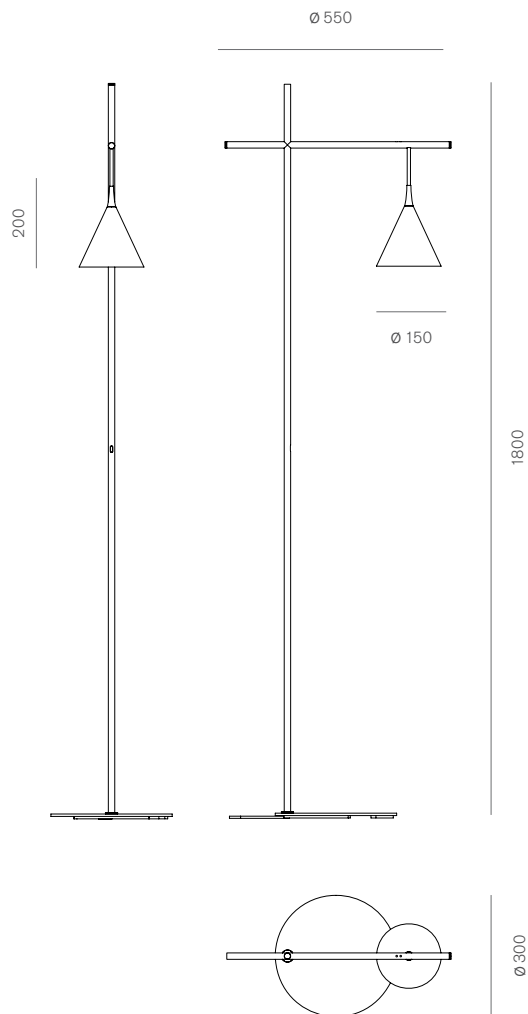

- CG-051WXS-WH- (Bianco / White)
- CG-051WXS-BL- (Nero / Black)
- CG-051WXS-GO- (Oro / Gold)

Lampada da parete a luce diretta.  
Wall lamp with direct light.

Verniciato bianco, nero, oro / Varnished white, black, gold  
Acciaio e alluminio / Steel and aluminium

Led / 17W / 230V / 1700 Lumen / 90 Cri  
2700 K / A+ / Dimmer



- CG-050FXS-WH- (Bianco / White)
- CG-050FXS-BL- (Nero / Black)
- CG-050FXS-GO- (Oro / Gold)

Lampada da lettura a luce diretta.  
Lecture lamp with direct light.

Verniciato bianco, nero, oro / Varnished white, black, gold  
Acciaio e alluminio / Steel and aluminium

Led / 25W / 24V / 2361 Lumen / 80 Cri / 2700 K  
A++ / Dimmer a 4 intensità / 4 intensities of light  
Cavo in tessuto nero 200 cm / Black fabric cave 200 cm



Carlo Guglielmi, 2020

# Cono

terra / floor

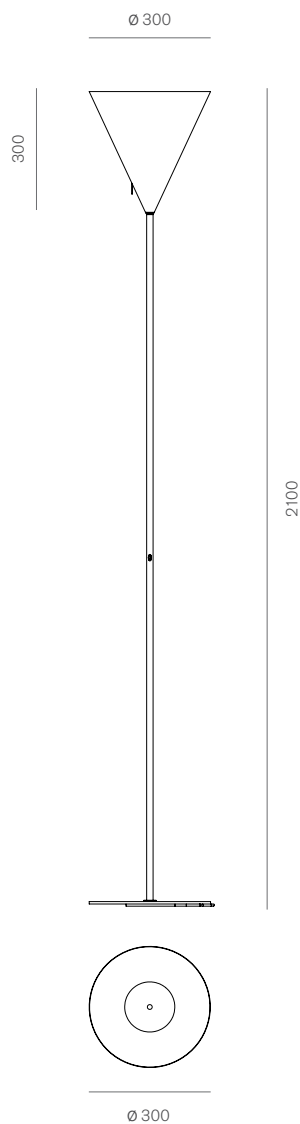

terra / floor

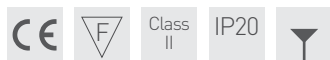
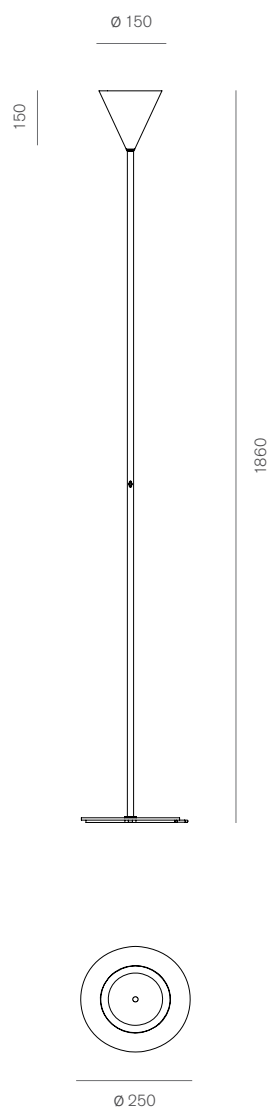

- CG-049FS-WH- (Bianco / White)
- CG-049FS-BL- (Nero / Black)
- CG-049FS-GO- (Oro / Gold)

Lampada da terra a luce indiretta.  
Floor lamp with indirect light.

Verniciato bianco, nero, oro / Varnished white, black, gold  
Acciaio e alluminio / Steel and aluminium

Led / 25W / 24V / 2361 Lumen / 80 Cri / 2700 K  
A++ / Dimmer a 4 intensità / 4 intensities of light  
Cavo in tessuto nero 200 cm / Black fabric cave 200 cm

- CG-049FXS-WH- (Bianco / White)
- CG-049FXS-BL- (Nero / Black)
- CG-049FXS-GO- (Oro / Gold)

Lampada da terra a luce indiretta.  
Floor lamp with indirect light.

Verniciato bianco, nero, oro / Varnished white, black, gold  
Acciaio e alluminio / Steel and aluminium

Led / 25W / 24V / 2361 Lumen / 80 Cri / 2700 K  
A++ / Dimmer a 4 intensità / 4 intensities of light  
Cavo in tessuto nero 200 cm / Black fabric cave 200 cm





Cono

Carlo Guglielmi





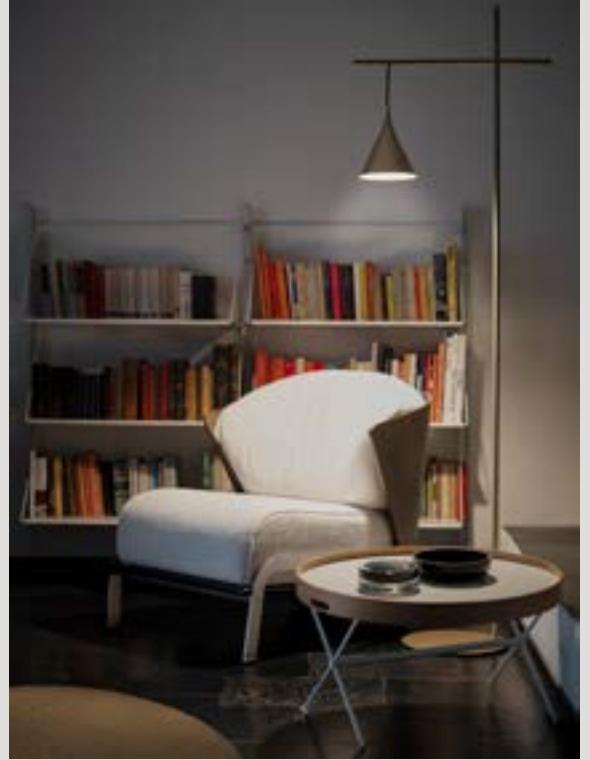







Carlo Guglielmi, 2020

# Piccola Boa

Ispirato dalle atmosfere orientali riconducibili alle lanterne cinesi, Piccola Boa è un sistema di lampade con immagine e luce di sofisticata presenza. Tutte le versioni sono dotate di due schede LED. La versione da lettura è provvista di un regolatore di luce a sfioramento che consente la possibilità di ottenere quattro livelli di intensità di luce diversi. Le versioni sospensione e parete possono essere regolate da dimmer da predisporre a parete al momento dell'installazione. Su richiesta del cliente si possono realizzare sospensioni a più elementi.

Inspired by the oriental atmospheres of the Chinese Lanterns, Piccola Boa is a system of lamps with sophisticated image and light. All versions have 2 LED boards. The reading version is equipped with a touch light regulator giving the possibility to obtain 4 different levels of light intensity. The suspension and the wall versions can be regulated by dimmers to be put on the wall. Multiple elements suspensions can be made on customer's request.

# Piccola Boa

sospensione / pendant

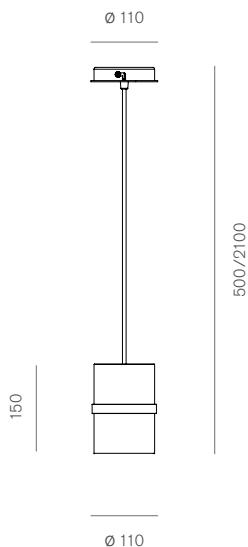

parete / wall

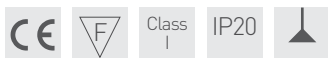
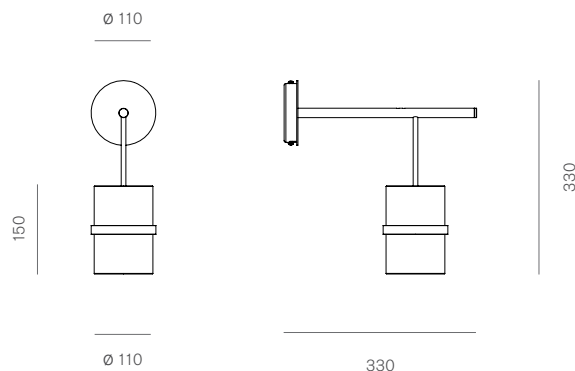

● CG-041PS-NI- (Nickel / Nickel)

Lampada da sospensione a luce diretta e indiretta  
Pendant lamp with direct and indirect light

Struttura in alluminio satinato e nichelato.  
Vetro soffiato opalino acidato  
Satin and nickel aluminium structure.  
Frosted opaline blown glass

Led / 2x7W / 230V / Lumen: 700 diretta/direct,  
700 indiretta/indirect / 90 Cri / 2700 K / A++ / Dimmer  
Cavo in tessuto nero 200 cm / Black fabric cave 200 cm

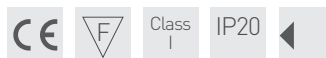

● CG-042WS-NI- (Nickel / Nickel)

Lampada da parete a luce diretta e indiretta  
Wall lamp with direct and indirect light

Struttura in alluminio satinato e nichelato.  
Vetro soffiato opalino acidato  
Satin and nickel aluminium structure.  
Frosted opaline blown glass

Led / 2x7W / 230V / Lumen: 700 diretta/direct,  
700 indiretta/indirect / 90 Cri / 2700 K / A+  
Dimmer

Carlo Guglielmi, 2020

# Piccola Boa

parete / wall

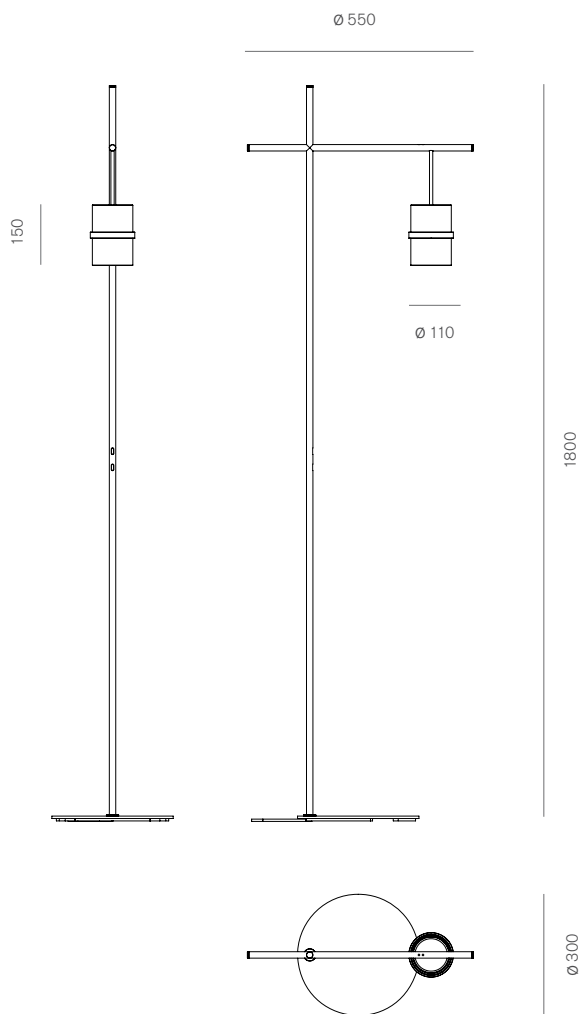

## ● CG-043FS-NI- (Nickel / Nikel)

Lampada da lettura a luce diretta e indiretta  
Lecture lamp with direct and indirect light

Struttura in alluminio satinato e nichelato.  
Vetro soffiato opalino acidato  
Satin and nickel aluminium structure.  
Frosted opaline blown glass

Led / 2x10W/24V / Lumen: 1476 diretta/direct,  
1476 indiretta/indirect / 80 Cri / 2700 K / A++  
Dimmer 4 intensità / 4 intensities of light  
Cavo in tessuto nero 200 cm / Black fabric cave 200 cm





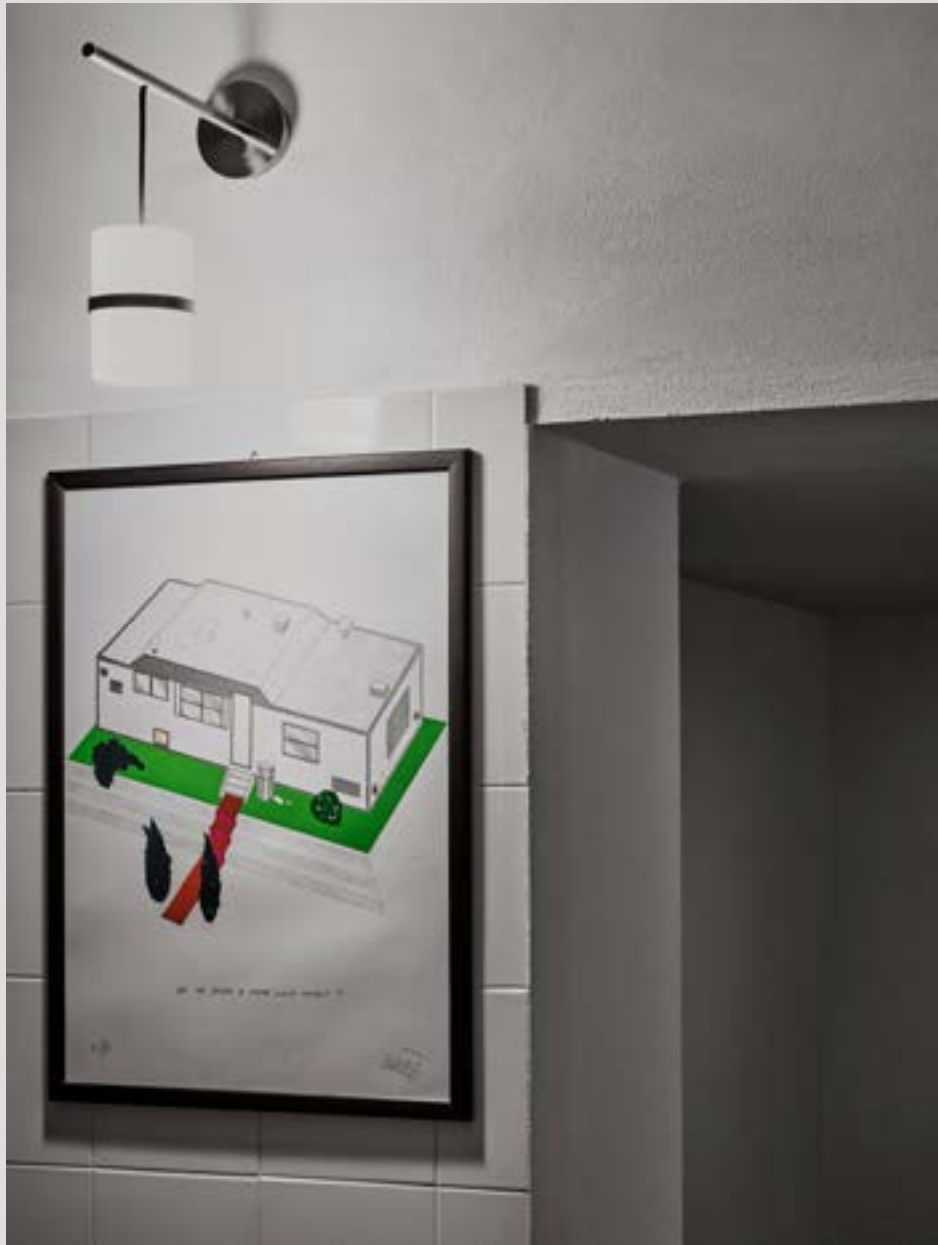

Piccola Boa

Carlo Guglielmi



Carlo Guglielmi, 2020

# Tambù

Il nome Tambù è abbreviativo di Tamburello, sport e gioco praticato in molte regioni italiane. La scelta del nome deriva dal fatto che l'elemento diffusore caratterizzante l'intero sistema ricorda nella forma quella di un tamburello. L'elemento diffusore incorpora due fonti luminose costituite da due schede LED che consentono 3 possibilità di illuminazione: diretta, indiretta o abbinata in simultanea. Le versioni terra e lettura sono dotate di regolatore di luce a 4 livelli, le versioni a sospensione e parete possono essere regolate da dimmer installabili a parete. Su richiesta la tipologia a sospensione consente delle composizioni a più elementi.

The name Tambù is a nick-name for Tamburello, sport and game frequently played in many Italian regions. The choice of the name comes from the fact that the diffuser characterizing the entire system resembles that of a tambourine. The diffuser element incorporates two sources of light consisting of 2 LED cards that allow 3 lighting possibilities: direct, indirect or combined simultaneously. The floor and reading versions are equipped with a 4-level light controller while the suspension and the wall versions can be regulated by wall-mounted dimmers. On request the suspension model can be custom-made with more elements.



Carlo Guglielmi, 2020

# Tambù

sospensione / pendant

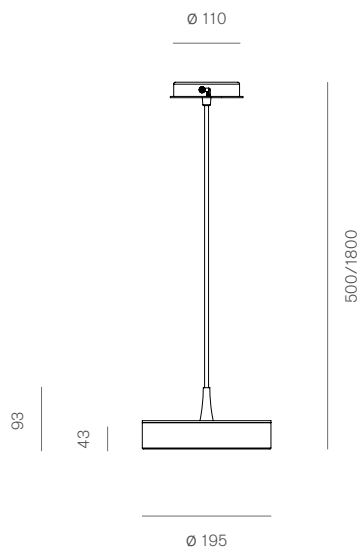

parete / wall

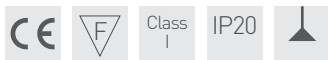
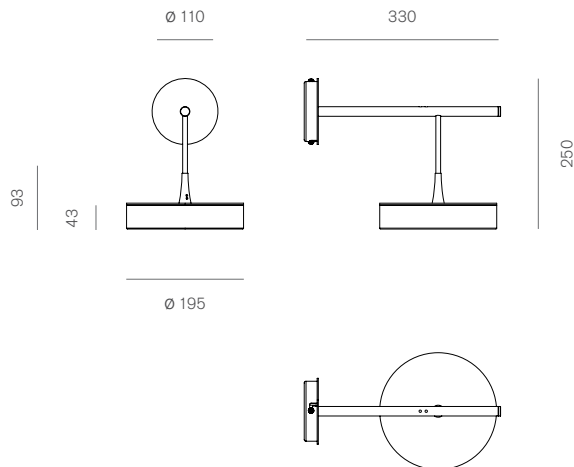

- CG-044PM-WH- (Bianco / White)
- CG-044PM-BL- (Nero / Black)
- CG-044PM-GO- (Oro / Gold)

Lampada da sospensione a luce diretta e indiretta  
Pendant lamp with direct and indirect light

Struttura in acciaio verniciato bianco, nero, oro  
Varnished steel structure in white, black, gold

Led / 2x17W / 230V / Lumen: 1700 indiretta / indirect  
1700 diretta / direct / 90 Cri / 2700 K  
A++ / Dimmer / Cavo in tessuto nero 200 cm  
/ Black fabric cave 200 cm



- CG-045WM-WH- (Bianco / White)
- CG-045WM-BL- (Nero / Black)
- CG-045WM-GO- (Oro / Gold)

Lampada da parete a luce diretta e indiretta  
Wall lamp with direct and indirect light

Struttura in acciaio verniciato bianco, nero, oro  
Varnished steel structure in white, black, gold

Led / 2x17W / 230V / Lumen: 1700 indiretta / indirect  
1700 diretta / direct / 90 Cri / 2700 K / A+ / Dimmer

Carlo Guglielmi, 2020

# Tambù

parete / wall

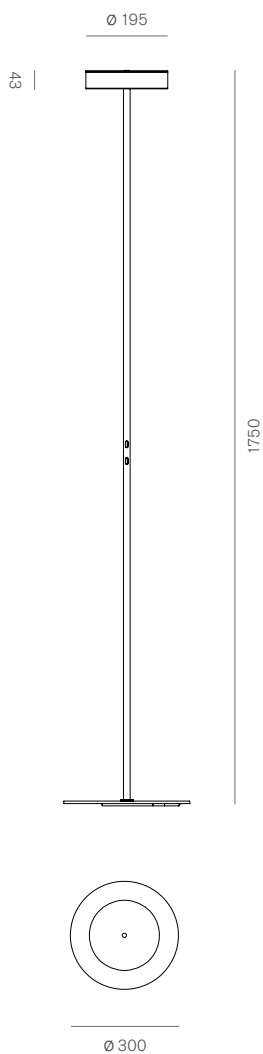

terra lettura / floor lecture

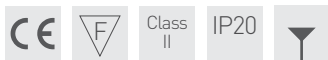
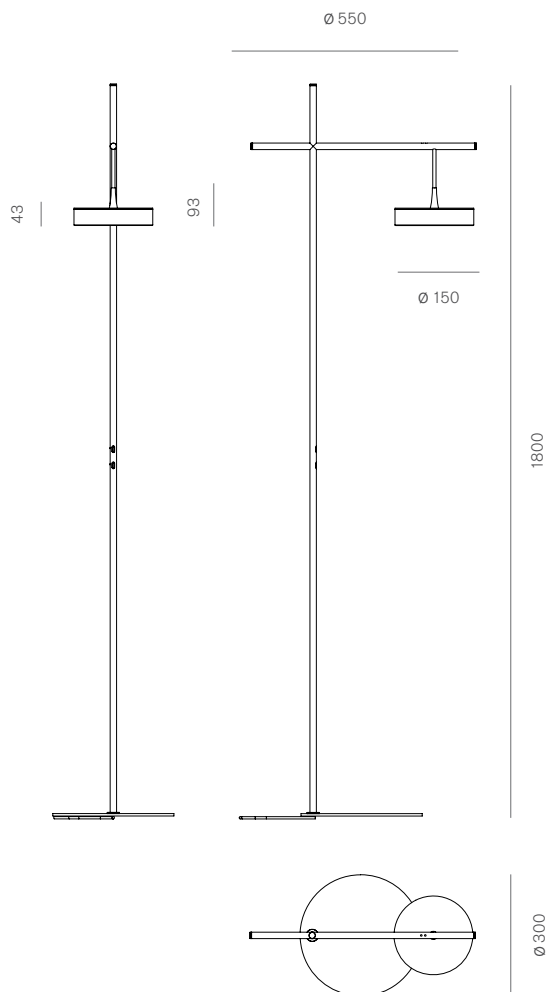

- CG-046FM-WH- (Bianco / White)
- CG-046FM-BL- (Nero / Black)
- CG-046FM-GO- (Oro / Gold)

Lampada da terra a luce diretta e indiretta  
Floor lamp with direct and indirect light

Struttura in acciaio verniciato bianco, nero, oro  
Varnished steel structure in white, black, gold

Led / 20+15W / 24V / Lumen: 1638 indiretta / indirect  
2100 diretta / direct / 80 Cri / 2700 K  
A++ / Dimmer a 4 intensità / 4 intensities of light  
Cavo in tessuto nero 200 cm / Black fabric cave 200 cm

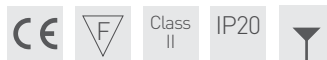

- CG-047FM-WH- (Bianco / White)
- CG-047FM-BL- (Nero / Black)
- CG-047FM-GO- (Oro / Gold)

Lampada da lettura a luce diretta.  
Lecture lamp with direct light.

Struttura in acciaio verniciato bianco, nero, oro  
Varnished steel structure in white, black, gold

Led / 20+15W / 24V / Lumen: 1638 indiretta / indirect  
2100 diretta / direct / 80 Cri / 2700 K  
A++ / Dimmer a 4 intensità / 4 intensities of light  
Cavo in tessuto nero 200 cm / Black fabric cave 200 cm







Filippo Taidello, 2020

# Phi

A completamento delle versioni da parete e sospensione ecco la Phi da terra. L'elemento diffusore in vetro soffiato e alluminio è fissato su uno stelo di sezione rettangolare in nichel satinato. La lampada è dotata di un regolatore di luce a sfioramento posizionato sullo stelo, che consente l'emissione della luce su 4 livelli diversi.

In addition to the suspension and the wall lamps here is the floor Phi to complete the series. The diffuser in blown glass and aluminium is fixed on a rectangular section stem in satin nickel finish. The lamp is equipped with a touch light regulation on the stem which allows the light emission on 4 different levels.

Filippo Taidelli, 2020

# Phi

parete / wall

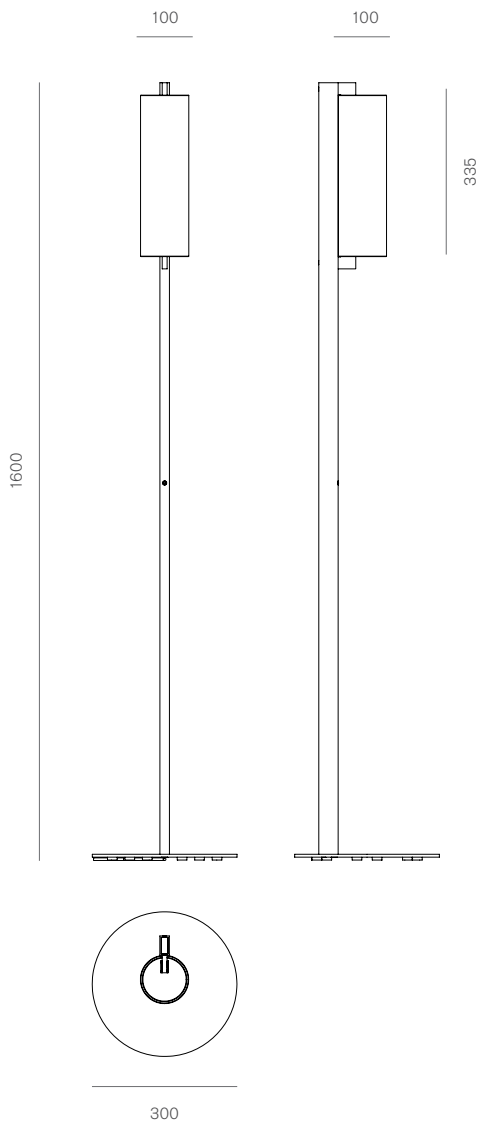

○ FT-040FM-WH- (Nickel e bianco / Nikel and white)

Lampada da terra a luce diffusa  
Floor lamp with diffused light

Diffusore in vetro soffiato opalino acidato. Struttura  
in alluminio nickel satinato. Base in acciaio nickel satinato.  
/ Frosted opalin blown glass diffuser. Satin nickel  
aluminium structure. Satin nickel steel base

Led / 20x10W / 24V / 1776 Lumen / 80 Cri / 2700 K  
A++ / Dimmer a 4 intensità / 4 intensities of light  
Cavo in tessuto nero 200 cm / Black fabric cave 200 cm























**Codice prodotto**  
Product Code

**MR- 002 TM- WH-**

Iniziali progettista / Designer	Numero progressivo / Number	Tipologia e misura / Typology and Size	Colore / Color
---------------------------------------	-----------------------------------	---	-------------------

<b>Progettista</b> Designer	<b>Numero</b> Number	<b>Tipologia</b> Typology	<b>Misure</b> Size	<b>Colore</b> Color
PLC Pierluigi Cerri	001	C Ceiling Plafone	XS Extra Small	 WH- White/Bianco
MDL Michele De Lucchi	001	F Floor Terra	S Small	 BL- Black/Nero
CG- Carlo Guglielmi	001	O Outdoor Esterno	M Medium	 ANGO Anodized Gold Anodizzato Oro
BMT Benedetta Miralles Tagliabue	001	P Pendant Sospensione	L Large	 ANP Anodized Polished Anodizzato Lucido
P+F Parisotto+ Formenton Architetti	001	T Table Tavolo	XL Extra Large	 B-B Brass/Bronze Ottone/Bronzo
P+A Park Associati	001	W Wall Parete		 BR- Bronze/Bronzo
DP- Daniela Puppa	001			 CH- Champagne
FR- Franco Raggi	001			 CO- Copper/Rame
MR- Michele Reginaldi	001			 GF- Green Forest Foresta Verde
AS- Attilio Stocchi	001			 GO - Gold/Oro
FT- Filippo Taidelli	001			 NI- Nikel/Nickel
CZ- Cino Zucchi	001			 NIBL Nikel Black Nickel Nero
				 NISA Nikel Sandblasted Nickel Sabbiato
				 RE- Red/Rosso

## Simboli Symbols

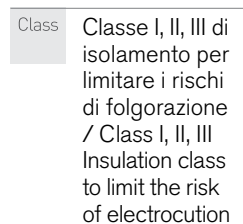
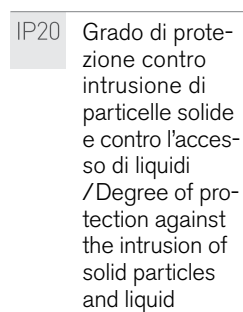
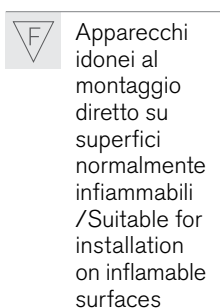
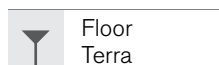
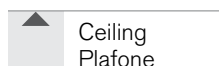

Le misure sono espresse in millimetri  
/All dimensions are in millimeters

Specifiche del prodotto soggette a modifiche senza avviso.  
Per ulteriori informazioni fare riferimento al nostro sito  
/Product specifications subject to change without notice.  
Please check our site to updated information

**Firmamento Milano 2017 s.r.l.**  
Viale di Porta Vercellina 7, 20123 Milano  
tel 0039 02 928503  
[info@firmamentomilano.com](mailto:info@firmamentomilano.com)  
[www.firmamentomilano.com](http://www.firmamentomilano.com)

[amministrazione@firmamentomilano.com](mailto:amministrazione@firmamentomilano.com)  
[comunicazione@firmamentomilano.com](mailto:comunicazione@firmamentomilano.com)  
[commerciale@firmamentomilano.com](mailto:commerciale@firmamentomilano.com)  
[export@firmamentomilano.com](mailto:export@firmamentomilano.com)

**Art Direction**  
Andrea Puppa  
Francesca Ceccoli

**Photography by**  
Marco Menghi